

Track Tester

DC & DCC O & G Gauge OO HO N Gauge



- Quickly checks track for power faults
- Small & Larger Versions - for N gauge to G gauge!
- Multicolour LED Indicates the DC polarity, or DCC, or a fault

Buffer Lights

WIRE FREE DC & DCC O Gauge OO HO N Gauge



- Realistic stop light for any siding - fits most buffer stops
- Simply clips onto track - No wires!
- On DCC both lights are on constantly
- On DC one light is on & varies with speed

DCC Fitted Digital Signals

DCC WIRE FREE OO HO



- Signal with DCC decoder built in - No CV programming
- Easy to fit and use - can just plug direct into track - no wires!
- Wide range available - also available with Feathers and Theatres

One-Touch DCC™ Point Controllers

DCC ANY GAUGE



- Control points and uncouplers using DCC
- Work with most solenoid point motors - Built in CDU
- Just connect 2 wires to DCC rails - No CV Programming!
- Easy screw terminals - no soldering

LFX Lighting Effect Controllers

DC & DCC ANY GAUGE



- Easy way to add lighting effects to your layout
- Wires screw in - no resistors or soldering - LEDs included
- Powered by 9v battery, 8-16V DC or DCC
- On DC the effect is on when powered - On DCC it can be controlled

Level Crossing - Ready Assembled

DC & DCC OO HO N Gauge



- Power from 9-16v DC, DCC or a 9v battery - available in single & pairs
- Light and sound - all connections easy push fit
- Includes 2 x Peco static level crossing barriers
- Can be turned on automatically using a Track Sensor

Traffic Lights - Ready Assembled

DC & DCC OO HO



- Power from 9-16v DC, DCC or 9v battery - 2 Wire connection
- Realistic standard UK sequence and timing varies randomly
- Fully assembled - drill hole in baseboard & connect to power

Track Sensor

DC & DCC OO HO N Gauge



- Trigger level crossings and change semaphore signals
- Power from 12-16v smooth DC or DCC
- Can be used to trigger Sound Track, Smart Screen, Relays
- Four outputs for direct connection to LEDs for occupancy, FX

Mimic Switches & Lights

DC & DCC ANY GAUGE

- Make a mimic panel to control Layout Link items - Single wire to control
- Link to Track Sensors or Sensor Signals and LEDs show occupancy & signal status
- Link to Sensor Signals to manually override and switch route indicators on/off

Smart Lights - Easy to fit Lighting Effects

DC & DCC ANY GAUGE



- Small - Just 1cm x 1cm x 0.3cm with 2 wires
- Power by 9-16v DC, 9v battery, or direct to DCC which can control some effects
- Just connect and go - no setting up required
- Disco / Emergency / Real Fire / TV / Welding / Random / Programmable

Automatic Tail, Firebox & Loco Lights

DC & DCC AUTO WIRE FREE ANY GAUGE



- No switch - senses motion & turns on!
- Turns off automatically 4 minutes after stopping
- No pickups, wires or soldering - LED just plugs in
- Fit in brake vans, coaches, loco, wagons etc
- Runs for ages on 2032 button battery - LEDs & battery included

Sound for your layout

DC & DCC AUTO WIRE FREE ANY GAUGE



- Sound capsule with no wires - runs from a battery - built in speaker
- No connections to track so work with both DC & DCC
- Motion activated - switches on when train moves! Real Sounds!
- Tiny - 25mm x 20mm x 12mm - N gauge fitting guide available
- Record your own sounds and play them back on your layout!
- Record 4 tracks upto 35 seconds each - Lock to protect favourites
- Portable - use with 9v battery to take out & record sounds
- Power from DC or DCC - Use Track Sensors or DCC to trigger sounds
- Background sounds for your layout - built in speaker & volume
- Power from DC or DCC - on DCC sounds can be triggered
- Lineside • Station Steam • Station Modern • Urban • Rural

Signal Kits

DC & DCC OO HO



Every kit includes the signal head, aluminium post & base plus detailing kit

- Low cost - adapt to your own design
- Control by switches or signal controller
- LEDs are prefitted to a narrow PCB
- Ground signals - modern & original
- Feather & Theatre kits available
- Signal Head only for gantries etc

SC2 - Signal Controller



5 060325 130528

Signal Controllers

DC & DCC AUTO ANY GAUGE

- DCC Signal Controllers - Wire in any LED signals to control from DCC accessory address
- Automatic Signal Controllers - Make any LED signal kit into an Automatic Signal!
- Dapol Semaphore Controllers - Control Dapol Semaphores by DCC or automatically

Automatic Sensor Signals

WIRE FREE DC & DCC OO HO



- Detects train and changes signal automatically to red
- Used own & signal changes back to green after train short time
- Or link to other Sensor Signals for fully automatic block signalling
- Can be used on both DC & DCC - Feather & Theatre versions

Automatic Coach Lighting

DC & DCC AUTO WIRE FREE OO HO N Gauge



- Easy to fit - no wiring or switch - senses motion & turns on!
- Turns off automatically - fits most coaches - may be cut down
- No pickups or wires so works on regular DC & DCC
- Traditional warm white or modern cool white
- Also with tail light, sparking, door beeps and door light effects

Servo Controller

DC & DCC ANY GAUGE

- Controls standard radio control servo from DCC, Track Sensor or Mimic switch
- Ideal for animating Level Crossing barriers / gates, Slow points or signals, Coal hopper
- Easy to wire and set up - connects directly to DCC or 8-16 volts smooth DC supply

Relay Controller

DC & DCC ANY GAUGE

- Two channel Relay unit which can be controlled by Track Sensor, Sensor Signal or DCC
- Enables remote control of motors, solenoids, lamps etc
- Incorporates two heavy duty relays with changeover contacts rated at 8-24 volts at 3 A

Automatic Train Control

DC & DCC ANY GAUGE

- Link Sensor Signals to Relay Controller for automatic trains which stop at red lights!
- Can be used on DC or DCC Layouts
- Easy wiring: Sensor Signal link with one wire and Isolated braking section two wires.
- Also supports ABC fitted DCC Loco's for gradual slow down and speed up with sound

Tools, LEDs & Accessories

ANY GAUGE

- We offer a range of LED packs, battery holders, wire, switches & terminals
- Also handy modelling tools including precision cutters, drill bits & spare batteries

Smart Screen

DC & DCC OO HO



- Real working animated screen - customise with your messages
- Use DCC to program - then can be run on DC or DCC
- Trigger messages with DCC, switches, track sensors or just cycle
- Message can change with direction of train on both DC & DCC
- Display upto 10 different messages - can also show real time clock
- Range of enclosure available - Programming service available
- Small - w 31mm x h 9.5mm x d 4.5mm
- Stationary top line - bottom line automatically scrolls

SEE WWW.TRAIN-TECH.COM OR ASK FOR FREE COLOUR BROCHURE



Train-Tech
Model Technology Made Easy

SC2 DCC Signal Controller

3 or 4 aspect or 2 aspect with route

- Control your Signals by DCC controller or PC
- Easy One-Touch DCC™ - no CV programming!
- Works with most LED colour light signals
- Just 2 wires to nearest track - reduces wiring
- Connect Signal LEDs direct - no resistors!
- LEDs fade as they change - just like real thing!
- Can synchronise to other Signals and points

www.Train-Tech.com

See our website, your local model shop or contact us for a free colour brochure
Train-Tech, Gagemaster House, Gagemaster Way, Ford Road, Arundel, BN18 0BN
Telephone 01903 884321 • email train-tech@gagemaster.co.uk

SC2 - Signal Controller for a 3, 4 aspect or 2 aspect +route indicator LED signal using DCC

CAUTION - ALWAYS SWITCH OFF POWER TO YOUR LAYOUT BEFORE CONNECTING THIS CONTROLLER

This Signal Controller incorporates a DCC decoder to enable it to be wired directly to the track and be operated by any controller or computer which is capable of controlling DCC accessories. Please read these instructions before connecting or fitting your controller.

1 CONNECTIONS

The SC2 is a Signal Controller designed to control a 3 or 4 aspect LED signal or a 2 aspect plus route indicator LED signal using DCC. **Switch off power before connecting!**

Connecting the SC2 to DCC

Connect the SC2 DCC input terminals to nearby rails or the DCC controller output.

Connecting the signal LEDs

There are a wide range of LED Colour Light signals available and they are usually supplied with LEDs already preconnected. LEDs are polarised and so only light when connected one way. Either the + or - pin of every LED needs to be connected together as a 'common' wire connection - this is often prewired by the signal manufacturer and the instructions for the signal should show the polarity connections.

The SC2 works with either common + or - connected LEDs, just connect the common wire to either + or - as marked under the SC2. The example below shows common negative.

Note you do not need to use resistors in series with LEDs as they are built into the controller (unless you want to make them less bright).

Example 1: 3 or 4 aspect signal

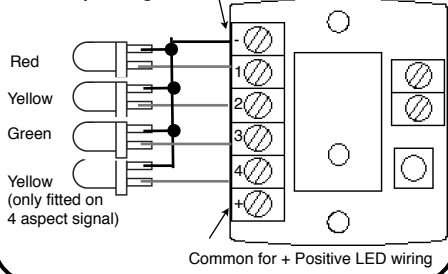

Using Train-Tech signal kits with the SC2

We offer a range of low cost Signal Kits which are accurately modelled to British Outline OO scale and make ideal partners for our Signal controllers. Signal kits SK4/5 are 3 aspect & SK6 is 4 aspect (see over). Refer to the instructions supplied with your signal to identify the connections you need for each colour to this controller - you do not need to use resistors.

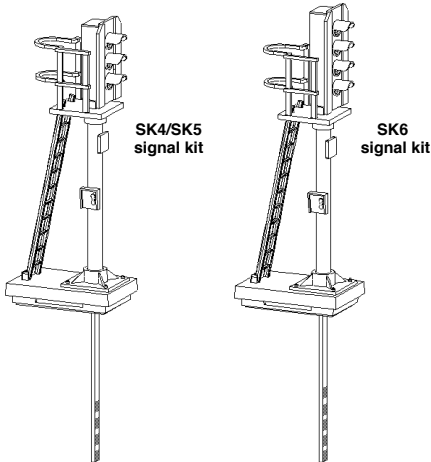

Using other manufacturers LED signals

Many other manufacturers LED signals are also widely available for both British Outline and overseas, many of which were tested with the SC2 in development. Most Colour Light Signals based on LEDs should be compatible, though check that you can remove or bypass resistors if fitted because these are already included inside the SC controller and will make LED lights quite dim if left connected. If white LEDs are used in signals like route indicators check that they can be connected independently because white LED's require a higher voltage than other colours and if prewired in series may not light or work correctly. Note: If you wish to control 2 aspect signals the SC1 is better suited and controls two 2 aspect signals.

Plug-In Digital Signals with DCC built in also available
For more details see Train-Tech.com

2 SETTING THE SIGNAL ADDRESS

You need to choose a DCC address for your signal. Because a DCC address can only have 2 or 'directions' or 'states' your multi aspect signal needs two addresses and so will use the address you choose and the next consecutive address, so ensure both addresses are unused for other accessories before programming. In our example we will use address 86 and so this signal will use both address 86 and 87.

• Set up your controller to control DCC accessories (your controllers instructions will show how to do this) and set your controller to the address you choose for this signal.

To program the signal controller address briefly press the 'Learn' button until the signal lights flash, then send either the ◀ or ▶ 'direction' command from your controller which you want to signal green. The signal will stop flashing, light up green and your signal is now programmed to the address you chose and also the next consecutive address.

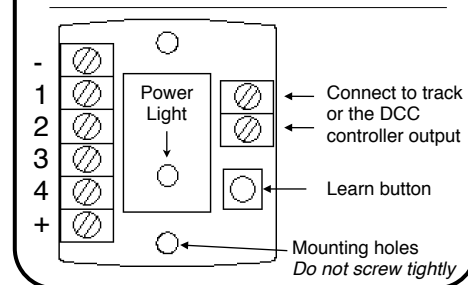

Troubleshooting

Step 2 above is the 'One Touch' DCC stage which programs the Signal address into the controller.

If it does not work:

- Check that one of the signal LEDs is lit - if not and DCC locos etc run correctly check the connections between your DCC Controller, the Signal Controller and between the LEDs and the controller
- If a Signal LED is lit double check that your DCC controller is in accessory addressing mode - note that these are completely different to Locomotive addresses and should be explained in your controller instructions. If not check carefully that your controller will control DCC accessories - most do but some of the low cost starter controllers such as the Bachmann E-Z command and Prodigy Express models do not.
- Try fitting the signal to another section of track (or use pieces of wire to temporarily connect it to another track)

If these steps fail please contact your supplier or Train-Tech for advice and Technical support.

Note

The Signal Controller module may get slightly warm when used for long periods which is quite normal.

Location board labels

These legends can be cut out and fitted to your signal. We suggest you use the DCC address you have programmed into your signal controller which will make the signal easier to identify and operate.

1	2	3	4	5	6	7	8	9	10
11	12	13	14	15	16	17	18	19	20
21	22	23	24	25	26	27	28	29	30
31	32	33	34	35	36	37	38	39	40
41	42	43	44	45	46	47	48	49	50
51	52	53	54	55	56	57	58	59	60
61	62	63	64	65	66	67	68	69	70
71	72	73	74	75	76	77	78	79	80
81	82	83	84	85	86	87	88	89	90
91	92	93	94	95	96	97	98	99	100
AD	CA	DA	ES	EN	GE	GY	MY	PN	NW
ABC	DEF	GHI	JKL	MNO	PQRST	UVW	XYZ		
ABC	DEF	GHI	JKL	MNO	PQRST	UVW	XYZ		

3 CONTROLLING THE SIGNAL

Control the signal by setting your controller to the DCC accessory address you chose and sending a ◀ or ▶ 'direction' command from your controller to change the signal colour (actual terms used for accessory control vary between controllers so refer to its instructions) In example 1 with a 3 or 4 aspect signal Address (86) ◀ or ▶ = Red or Green Address (87) ◀ or ▶ = Yellow or Double Yellow

Each signal can be controlled independently with its own unique address or can be easily synchronised to other DCC signals or points etc by giving them the same address as each other.

Using a 2 aspect signal with route indicator
A 2 Aspect signal with a route indicator, such as a feather, can also be controlled effectively with the SC2. Wiring it as below only allows the route indicator to light if the signal is green.

Controlling 2 aspect signal with route indicator
Address (86) ◀ or ▶ = Red
Address (87) ◀ or ▶ = Green or Green+ Route

Example 2: 2 aspect signal + route indicator

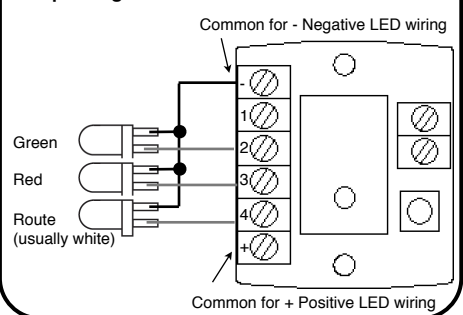

General information on using LEDs with models

LEDs are really useful lights which, unlike their conventional filament bulb predecessors, are robust, low power and if used correctly can effectively last forever. But there are important considerations to using them. Firstly LED stands for *Light Emitting Diode* and a diode is an electronic component which only works electrically in one direction, so always need to be fitted the correct way round to work correctly and last. Whilst LED's will work on AC (alternating current) for a while, continuous use on AC or reverse connection will reduce the life.

Most standard miniature LEDs which a modeller will use must only have a maximum voltage of 2 to 3 volts applied, so current flowing through the LED needs to be reduced and this is usually done by a resistor in series (in between), typically 1000 ohms for a 12 V supply. However to make wiring easier for modellers all Train-Tech LFX or Signal LED controllers already have resistors built in so that LEDs can connect directly to the module without the need for any resistors.

Train-Tech also offer packs of various LEDs for modellers and these always come with instructions and also suitable resistors for using them on a standard Model Railway 12V DC supply.

Connecting LEDs

As explained previously LEDs have a polarity and must be connected the correct way round to light. The most popular LEDs come in 3mm and 5mm diameter cases and look similar to this:



The best indication of polarity on this type of LED is to find the flat side on the round base. This side usually indicates the negative (Cathode) connection and the other wire the positive (Anode) connection to power.

Another really small LED we supply for some Train-Tech products looks like this:



There are many LEDs on the market and it is good to experiment, but check manufacturers data for specific connection information as there are no real standards.